



Reverse Voltage: 100Volts

Forward Current:20.0Amperes

Features

- ◇ Trench Schottky Barrier technology
- ◇ Ultra low forward voltage drop
- ◇ Low power loss,high efficiency
- ◇ Excellent low reverse leakages
- ◇ Excellent high temperature stability
- ◇ High current capability
- ◇ High forward surge capability
- ◇ Lead free finish ,Rohs and WEEE compliant.

Applications

- ◇ Switching diode
- ◇ Switching mode power supply(SMPS)
- ◇ DC/DC converter
- ◇ LED lighting
- ◇ Adapter for notebook and game station

Mechanical Data

- ◇ Moisture Sensitivity: MSL Level 1,per J-STD-020
- ◇ Terminals:Matte Tin Finish.
Solderable per MIL-STD-202 Method 208
- ◇ Case Material: Molded Plastic;
Molding compound meet UL Flammability ClassificationRating 94V-0
- ◇ Case:JEDEC TO-220AB,ITO-220AB,TO-252,TO-263

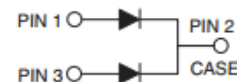
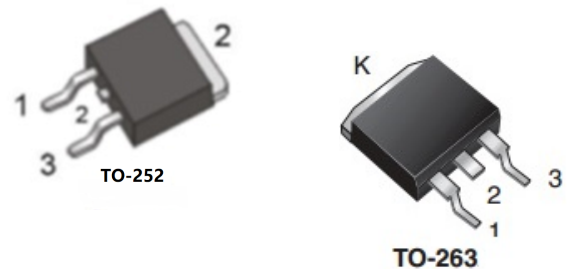
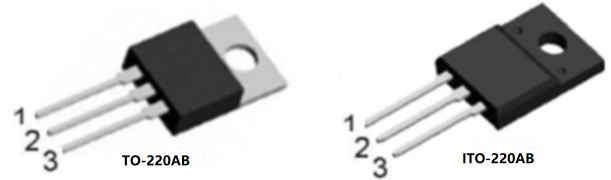

MAXIMUM RATING

Ratings at 25°C ambient temperature unless otherwise specified.

PARAMETER	SYMBOL	VALUE	UNITS	
Maximum repetitive peak reverse voltage	V_{RRM}	100	V	
Maximum RMS voltage	V_{RWS}	70	V	
Maximum DC blocking voltage	V_{DC}	100	V	
Maximum average forward rectified current	$I_{F(AV)}$	20	A	
per device Per diode		10		
Peak forward surge current 8.3ms half-sine-wave	I_{FSM}	200	A	
I^2t Rating for Fusing($t < 8.3ms$)	I^2t	166	A ² s	
Typical Thermal Resistance	TO-220AB	$R_{\theta JA}$	12.0	°C/W
		$R_{\theta JC}$	2.5	°C/W
		$R_{\theta JL}$	3.0	°C/W
	ITO-220AB	$R_{\theta JC}$	4.5	°C/W
	TO-252	$R_{\theta JC}$	2.5	°C/W
TO-263	$R_{\theta JC}$	2.5	°C/W	
Typical junction capacitance: VR=4.0v,f=1MHz	CJ	380	pF	
Junction temperature	T_J	150	°C	
Storage temperature range	TSTG	-55~150	°C	



ELELTRICAL CHARACTERISTICS

PARAMETER	TEST CONDITIONS	SYMBOL	VALUE			UNITS	
			Min	Typ	Max		
Breakdown voltage per diode(min)	IR=0.5mA	V _{BR}	100	-	-	V	
Instantaneous forward voltage	IF=10A per leg	TA= 25°C	VF	-	0.8€	0.85	V
		TA= 100°C	VF	-	0.75	-	V
		TA= 125°C	VF	-	0.73	-	V
	IF=5A per leg	TA= 25°C	VF	-	0.1 H	-	V
		TA= 100°C	VF	-	0.1 F	-	V
		TA= 125°C	VF	-	0.1 €	-	V
	IF=3A per leg	TA= 25°C	VF	-	0.1 2	-	V
		TA= 100°C	VF	-	0.1 0	-	V
		TA= 125°C	VF	-	0.1 8	-	V
Maximum DC reverse current @Rated DC Blocking Vlotage	TA= 25°C	IR	-	1.0	20	μ A	
	TA=125°C	IR	-	-	10000	μ A	

ORDERING PACK INFORMATION

Part No.	Packge	Pcking	Quatity(pcs/box)	Quatity(pcs/carton)
MBR20100CT	TO-220	50pcs/Tube	1000	5000
MBRF20100CT	ITO-220	50pcs/Tube	1000	5000
MBRD20100CT	TO-252	80pcs/Tube	4000	40000
MBRD20100CT	TO-252	2500pcs/Reel	2500	12500/25000
MBRB20100CT	TO-263	50pcs/Tube	1000	5000/10000
MBRB20100CT	TO-263	800pcs/Reel	800	4000/8000



RATING AND CHARACTERISTICS CURVES

FIG.1-FORWARD CURRENT DERATING CURVE

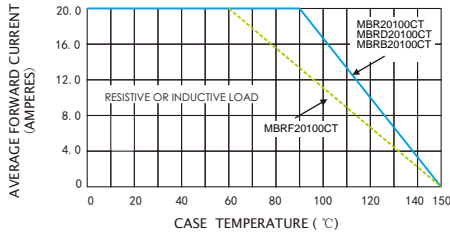

FIG.2-MAXIMUM NON-REPETITIVE PEAK FORWARD SURGE CURRENT

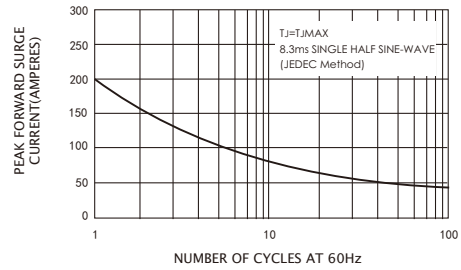

FIG.3-TYPICAL REVERSE CHARACTERISTICS

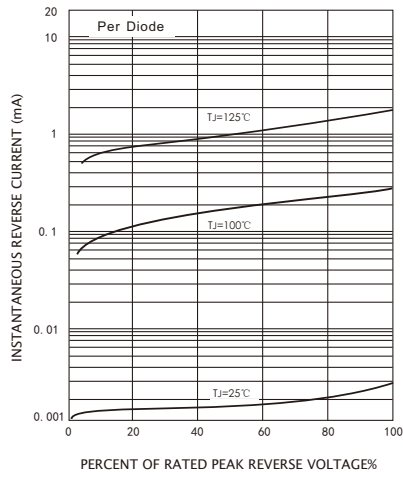

FIG.4-TYPICAL INSTANTANEOUS FORWARD CHARACTERISTICS

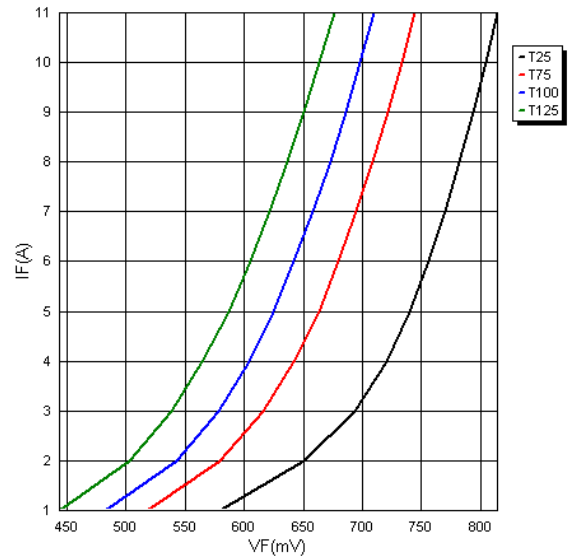
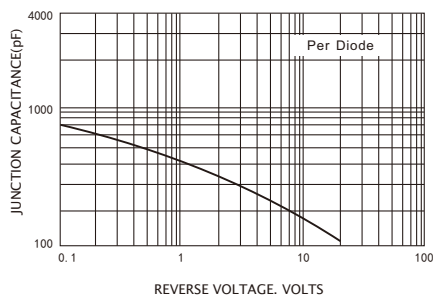

FIG.5-TYPICAL JUNCTION CAPACITANCE





PACKAGE OUTLINE DIMENSIONS

Dimensions in inches and (millimeters)

TO-220AB

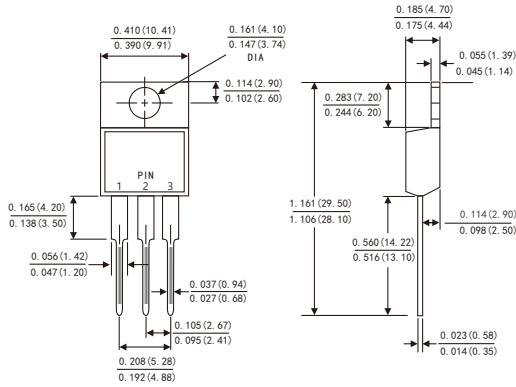

ITO-220AB

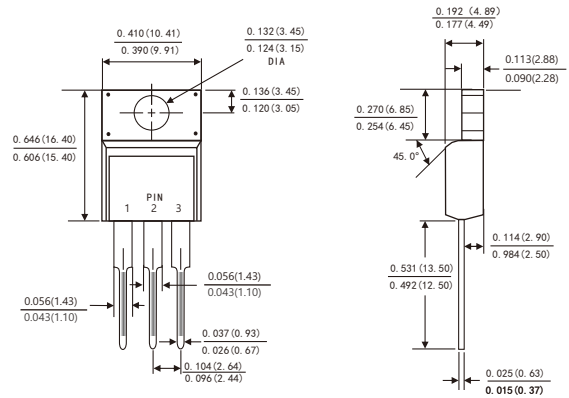

TO-263

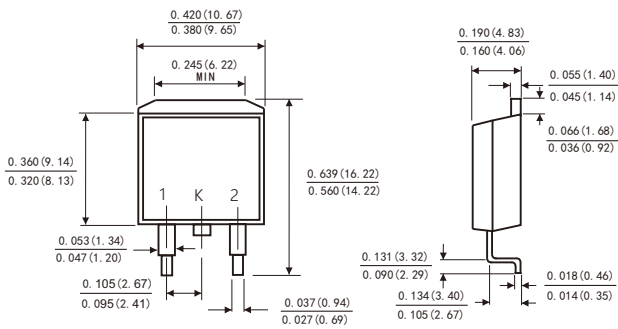

TO-252

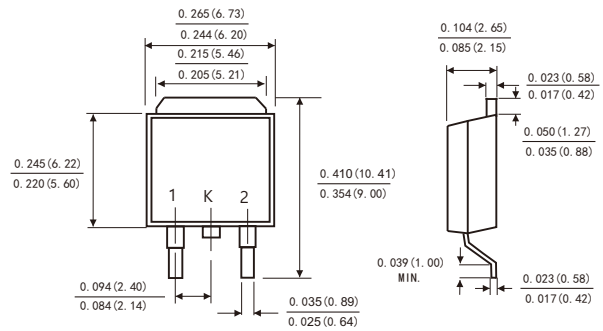

Suggested Pad Layout

(TO-263)

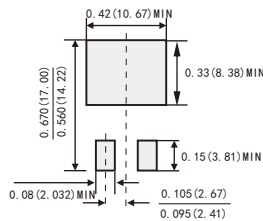

Suggested Pad Layout

(TO-252)

